



Port of Tauranga

Connecting New Zealand and the World



Port Operational Information

July 2015



Port of Tauranga

Connecting New Zealand and the World

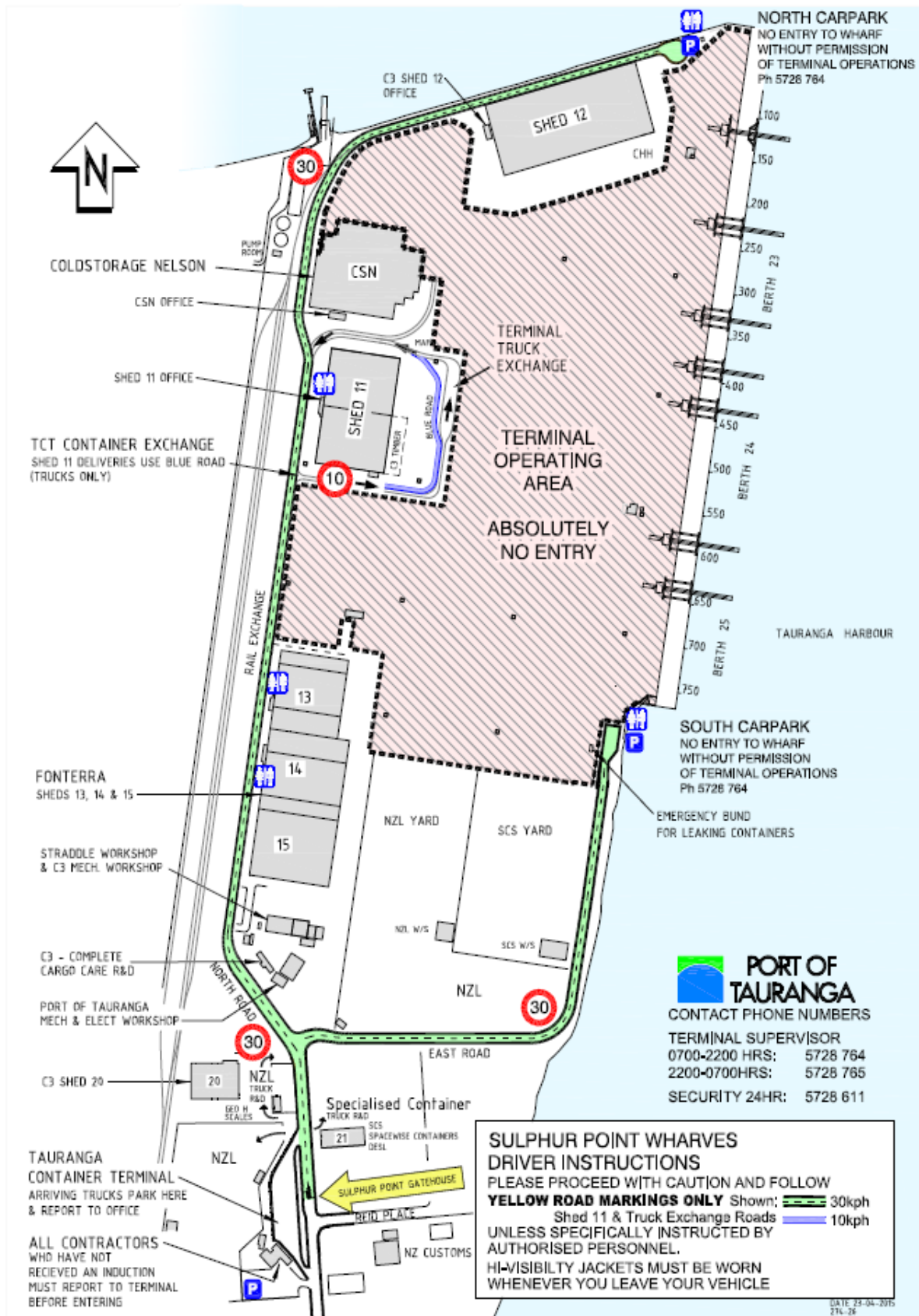

Port of Tauranga

Connecting New Zealand and the World

DATE 24-04-2015
274-28

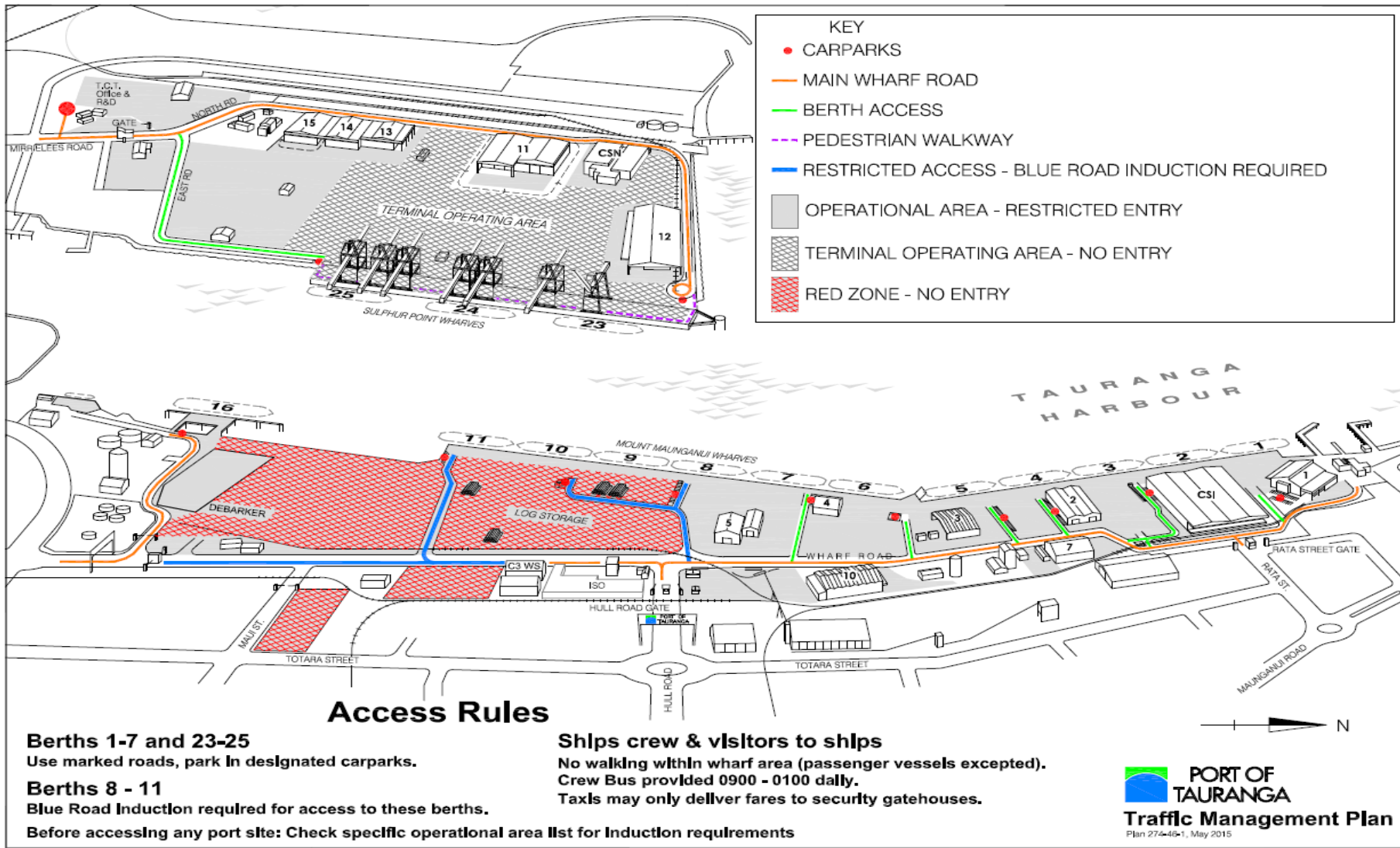

Metroport Auckland – A port without water

MetroPort Auckland, situated in the heart of South Auckland's manufacturing area, is the country's first inland dry port. The facility is part of a totally integrated transport system, linking the expertise and services of the Port and KiwiRail.

The Port of Tauranga is New Zealand's largest export port by volume, and has long been recognised as centre of positive change within the port sector.

KiwiRail, New Zealand's leading transport company provides the rail link between Tauranga and MetroPort.

A logical integration of services forms the basis of MetroPort Auckland's operations.

When a shipping line, which is contracted to use MetroPort, calls at the Port of Tauranga, import cargo destined for Auckland is offloaded at the Tauranga Container Terminal, and railed to MetroPort Auckland. From there it is distributed to its final destination. The same process happens in reverse for Auckland sourced export cargo. It is aggregated at MetroPort Auckland; railed to Tauranga; and loaded onto the vessel.

MetroPort Auckland offers a range of practical benefits to shipping lines, exporters and importers including:

- a choice of ports in the Auckland region
- efficient tracking of cargo through state of the art information technology
- guaranteed cargo delivery times
- direct delivery into South Auckland without having to rely on central Auckland's heavily congested roading and motorway systems
- Port of Tauranga's commitment to providing a seamless, efficient, cost-competitive, intermodal service

MetroPort Auckland was opened in May 1999 with the signing of its first major customer - Australia New Zealand Direct Line - and operations commenced June 1999. Through the North American Pacific South West (PSW) string vessel sharing agreement, P&O Nedlloyd, Hamburg Sud, Maersk and FANAL also became customers of MetroPort Auckland.

Around the same time as the PSW change, FESCO's Asian service FNZEL chose Tauranga as its sole North Island port call. The FNZEL service gave Auckland customers to Australia and the Far East the opportunity to experience MetroPort Auckland's benefits. This service has now become part of Hamburg Sud and is called ANZL. The port is serviced directly by the ANZL service include Manila, Hong Kong and Brisbane, opening up access to a wide range of feeder services throughout South East Asia.



Port of Tauranga

Connecting New Zealand and the World

One of the keys to the success of MetroPort is the speed and efficiency of the integrated transport system between the Auckland and Tauranga ports. The integrated transport system uses the EXPRESS2 database and Sparcs planning system, a specific train module for tracking containers between the two ports. More recently the Port has developed its interactive web based tool called ShuttleSelect which allows importers to choose the arrival delivery window at MetroPort that best suits the needs of their supply chain. MetroPort is the only intermodal supply chain in New Zealand that delivers the cargo closest to the end destination and when the customer wants it.

The Port Today

Mount Maunganui Wharf

A continuous concrete quay type wharf structure currently 2,055m long providing a nominal 11 berths plus a separate specialised 80m concrete dolphin type berth for tankers, cement, woodchips located to the south of the main quay.

These modern concrete structures include some of the strongest wharf structures in New Zealand. Berths 10 and 11 at the southern end of the quay are designed to support a 5 tonne per square metre distributed load and concentrated loads up to 50 tonnes. (Loading type "A" on chart). These berths also support the Liebherr multi purpose cranes.

MOUNT MAUNGANUI WHARF - QUAY DETAILS

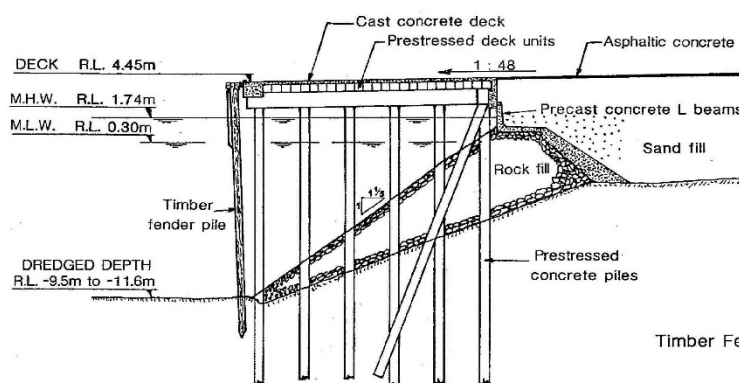

TYPICAL QUAY SECTION

NOTE
All R.L. (Reduced Level) relate to Port of Tauranga Datum.
Port of Tauranga Datum & Chart Datum are the same

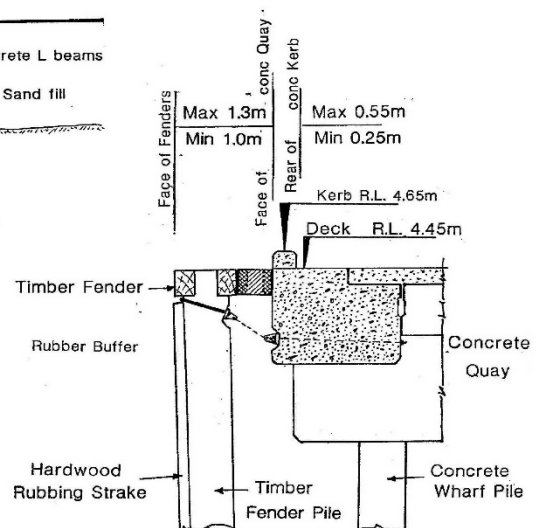

FENDER SYSTEM



Port of Tauranga

Connecting New Zealand and the World

The current Port draughts berth lengths are:

	LENGTH	DISTANCE FROM NORTH END			DEPTH	MAXIMUM DRAUGHT AT LW	CARGO USE
	(Metres)	(Metres)			(Metres)	(Metres)	
1	170	0	-	170	10.4	9.8	General, containers
2	170	170	-	340	10.4	9.8	General, containers
3	170	340	-	510	12.5	11.7	General, containers
4	170	510	-	680	12.5-9.5	11.7-9.0	General, containers
5	228	680	-	908	9.5	9.0	General, containers
6	150	962	-	1,112	10.4	10.0	General, containers
7	160	1,112	-	1,272	12.5	11.7	General, containers, bulk
8	180	1,272	-	1,452	12.5	11.7	General, containers, bulk
9	180	1,452	-	1,632	12.5	11.7	Logs, bulk
10	200	1,632	-	1,832	12.5	11.7	Logs, bulk
11	223	1,832	-	2,055	12.5	11.7	Logs, bulk
Cement/Tanker Tauranga - Sulphur Point					12.9	12.0	Petrol products, cement, woodchips
23	200	001	-	200	14.5	13.0	General, containers
24	200	200	-	400	14.5	13.0	General, containers
25	200	400	-	600	14.5	13.0	General, containers

Depth Alongside - Depths are metres below chart Datum or Lowest Astronomical Tide.

Draught - Permitted draught alongside.

The specialised dolphin type berth, draught 12.0m, is equipped for the discharge of liquid petroleum and chemical products, and bulk cement. Three berthing and two mooring dolphins allow large woodchip vessels to convey local woodchips for export. The berth also has special fire fighting equipment and its own watch office, which is manned whenever a ship is at berth.

Sulphur Point Wharf

Built on 60 hectares of reclaimed land, which was obtained from a dredging programme started in 1965, the new wharf was opened in April 1992. The first stage provides 600m of wharf on the eastern face, with a potential for expansion to 1,155m. A further 400m could be built on the northern face. Twenty-three hectares of paved open storage, which is floodlit, is now available. Two hectares of covered storage space has been erected, with a planned six hectares in the future.

Vessels of post-panamax size, which will be up to 290m in length with a 13.0m draught are able to berth at the Sulphur Point Wharf.

Container terminal facilities are available at Sulphur Point Wharf, utilising straddle carriers (18) and a computerised container tracking system (SPARCS).

Four gantry cranes, including three post-panamax size, are operating at Tauranga Container Terminal. Safe working load is 40 tonnes (with telescopic spreader) and up to 55 tonnes (with hook beam) for post-panamax cranes. A fleet of 18 straddle carriers operate within the container terminal.

Port Draught and Ship Length Criteria

Maximum Draught	High Water	13.0m
	Low Water	11.7m
Maximum Overall Length		290m

Vessels are handled inward and outward at various stages of the tide and sail around the clock.

All vessels are assigned an individual grade inward and outward (A to E) dependant on LOA, draft, manoeuvrability, engine power and past history, with grade A vessels having a tidal flow of up to 1.5 kts and grade E vessels being non tidal.

Pilotage is compulsory for all merchant vessels over 100 tonnes gross register, except those commanded by an "exempted" master.

Pilotage District

All the waters of that portion of the harbour of Tauranga having:

- 1 As its outward seaward limit an arc of a circle 2.5 nautical miles radius running from the landward boundary of the eastern foreshore of Matakana Island and thence into the Bay of Plenty and thence to the landward boundary of the foreshore of the mainland south-east of Trig Station A, Mount Maunganui, 37° 37' 55.56", 176° 10' 18.40"E, and having as its centre the said Trig Station A, Mount Maunganui, and



Port of Tauranga

Connecting New Zealand and the World

- 2 As its western limit a straight line running a north-westerly direction on a bearing of 335° from a point on the mainland, being 5.75 nautical miles on a bearing of 270° from the said Trig Station A, Mount Maunganui, such said part of the said straight line being from the landward boundary of the mainland across the harbour to the landward boundary of the Western Foreshore of Matakana Island.
(New Zealand Gazette, 11 May 1961, No 32, page 676.)

Bunkering

There are eight bunker points placed along the length of the Mount Maunganui Wharf and an additional bunker point situated at the cement/tanker berth. Light Marine Fuel Oil (LMFO) 40 and LMFO 180 is supplied through a 10" line to all bunker points at rates of up to 150 tonnes per hour. Marine gas oil is also available ex road tanker.

Bunkering on the Tauranga side of the harbour can be carried out by road tanker.

Port Communications

A listening watch is maintained at the Customer Service Centre, manned 24 hours a day seven days a week, for control and regulation of shipping, and is equipped with Radar AIS and VHF (Listening watch on VHF Channels 16 and 12, call "Tauranga Port Radio", call sign ZMH 70).

Pilot launches and tugs are equipped with VHF to facilitate communications during pilotage operations.

Port Security

Access to the wharf area is restricted to authorised persons only. Entry on to the port area is now controlled by barrier arms at all road gates. The Rata Street and Tasman Quay gates are only open to heavy vehicles and light vehicles carrying security access cards. The Hull Road gate is manned 24 hours a day, seven days per week, and is monitored by Customer Service Centre. Only heavy vehicles, authorised persons and visitors with legitimate business reason are permitted on to the Port. The gate at Sulphur Point on the Tauranga side of the harbour is manned 24 hours per day.

Cargo Handling

With the exception of seven Liebherr cranes (one multipurpose, three post-panamax and three twin lift) and numerous straddle carriers, mechanical equipment used on the wharves is owned and operated by private stevedoring companies. Fork trucks have capacities ranging from 0.5 tonne to 30 tonnes and log handling machines up to 40.82 tonnes. Cargoes are generally handled by on-board ships gear or by mobile cranes up to 50 tonne capacity.



Port of Tauranga

Connecting New Zealand and the World

Sulphur Point Container Cranes

Crane No 1 – Liebherr Tango 115 Super (1978)

The Liebherr Tango Super quayside crane has a span of 30.48m with an outreach over the water of 35m and a backreach behind the wharf of 10.7m. It can be fitted with automatic spreader beams for 20ft and 40ft containers or a 38.5 tonne capacity hook beam. The crane is powered by electricity with 400kw DC hoist motor, 80 kw DC trolley motor, 90 kw DC derricking motor, and 7 x 15.4 kw motors powering the gantry along the quay. Maximum continuous power consumption is 850 kVA. Maximum design speeds are:

Hoisting	45.7m/min fully laden
	91.4m/min half laden
Trolley	152m/min
Gantry along quay	36m/min

The crane can operate in wind speeds up to 72km/hr and has a lifting range of 42.3m being from 15.5m below quay rail to 26.8m above rail.

Cranes No 2, 6 and 7 - Three Liebherr Post-Panamax Cranes - Model P141L/Super (2x1991/1x 2003)

Each crane has a span of 30.48m (rail centre distance) with an outreach over the water of 43.0m and a back reach behind the landside rail of 13.20m. The 2 x 1992 cranes can be fitted with a telescopic spreader with SWL 40 tonnes or with a hook beam SWL 46.5 tonnes over entire outreach distance or 55 tonnes up to a waterside outreach of 30m. The 2004 crane has twin lift capability. Each crane is powered by electricity with 2 x 300 kw DC hoist motors, 110kw or 140 kw DC trolley motors, 8 x 25 kw or 30kw DC long travel motors and 1 x 95kw or 150 kw DC derricking motor. Maximum design speeds are:

Hoisting	60m/min	Fully laden	Acc time	1.5 secs
	150m/min	unladen	Acc time	3.0 secs
Trolley	200m/min			
Long travel speed	45m/min			

Above quoted hoist/lowering speeds are continuously variable and load dependent up to the maximum speed quoted above.

These cranes can operate in wind speeds up to 72 km/hr N/S and 80km/hr E/W and have a lifting range of 47.5m being 15.5m below quay rail and 32.0m above the rail.

Cranes No 3, 4 and 5 - Liebherr Crane - Model P157L Super Post-Panamax Cranes (2009, 2013, 2014)

This crane has twin lift capability, an outreach of 48m and a back reach of 15m. This crane can be used with a single lift spreader 20, 40, 45' with a SWL of 50 tonnes or a twin



lift (long twin 20') spreader with SWL of 60 tonnes over the full outreach. Hook beam SWL's are 71 tonnes full outreach and 80 tonnes limited to an outreach of 40m. This crane has 2 x 500kw DC Horst motors, 4 x 55kw DC Trolley motors and 8 x 30kw DC long travel motors. The Derrick motor is 1 x 180kw.

The consequent design spreads are:

Hoisting	70m/min	Laden	Acc Time	2.0sec
	175m/min	Empty	Acc Time	3.0sec
Trolley	220m/min	Laden	Acc Time	5/7sec
Long travel	45m/min	Empty	Acc Time	8/10sec

This crane can operate in wind speeds up to 72 km/hr N/S and 80km/hr E/W and have a lifting range of 54.4m being 17.5m below quay rail and 36.9m above the rail.



Port of Tauranga

Connecting New Zealand and the World



LIEBHERR TANGO 115 SUPER - S/N IR1318 - MODEL 2617
Mt Wharf 9/1979 Reloc. to Sulphur Pt 2/1999
SAFE WORKING LOADS
(TO MAX. OUTREACH)

MAXIMUM SWL UNDER THE LIEBHERR
HOOK BEAM - **38.5 TONNES**

MAXIMUM SWL UNDER THE LIEBHERR
40 FT TELESCOPIC SPREADERS - **32.8 TONNES**

MAXIMUM SWL UNDER THE NATSTEEL RAM
40 FT TELESCOPIC SPREADERS - **32.1 TONNES**

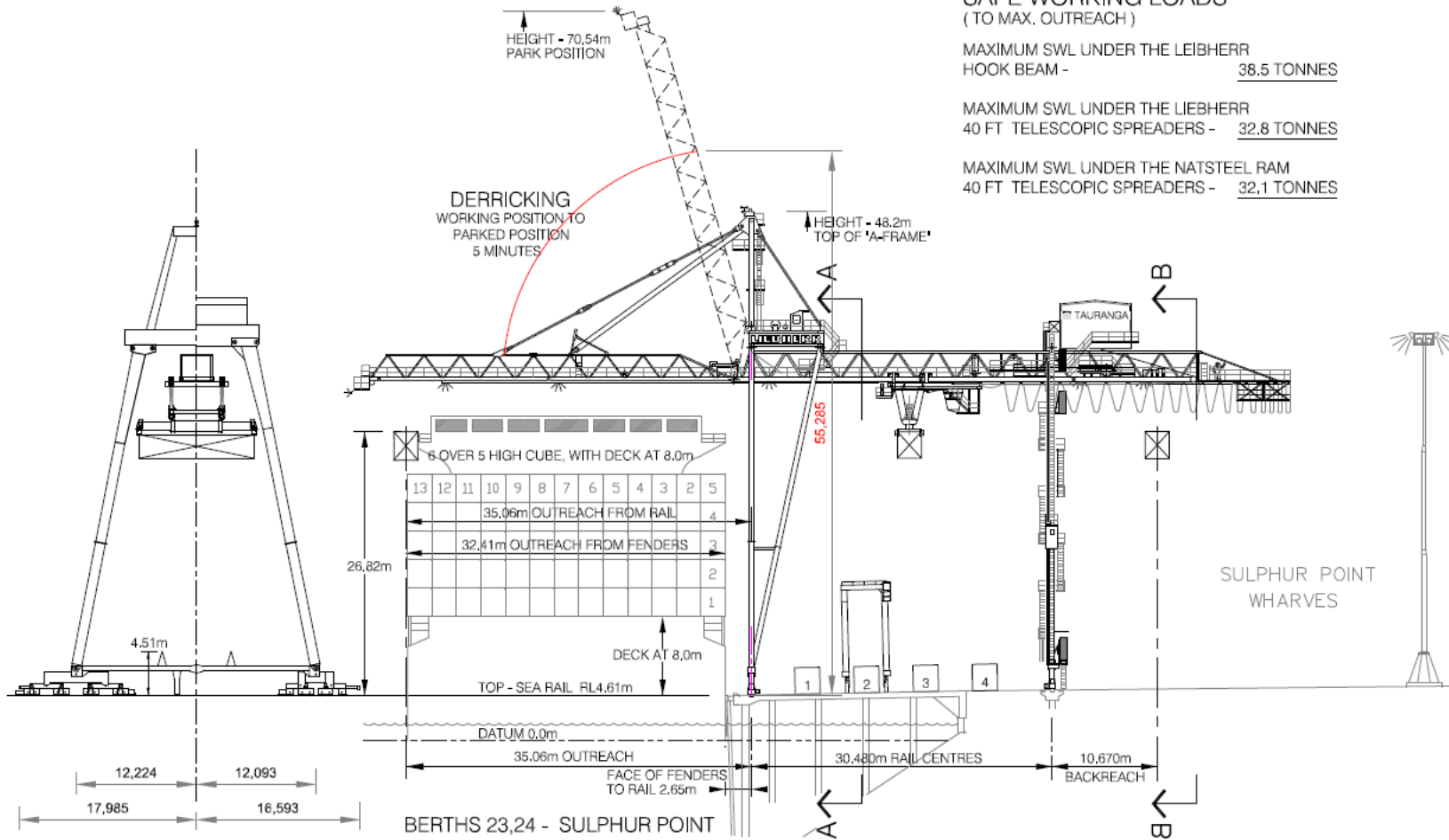

SECTION A-A WEST ELEVATION
(WATERSIDE LEGS) (LAND SIDE LEGS)

BERTHS 23,24 - SULPHUR POINT
NORTH ELEVATION



CRANE No.1 (1st) - LIEBHERR TANGO 115 SUPER - IR1318
DIMENSIONS & LOADS



HEIGHT 85.4m
ABOVE RAIL

LEIBHERR P141L SUPER (1991)
No2 (nee No1) S/N IR1446 , Same as No5 S/N IR1447
SAFE WORKING LOADS

MAXIMUM SWL UNDER THE LEIBHERR HOOK BEAM
TO MAX OUTREACH - **46.5 TONNES**
TO 32m OUTREACH (NO BACKREACH) - **55 TONNES**

MAXIMUM SWL UNDER THE 40FT TELESCOPIC SPREADERS - **40 TONNES**
(TO MAX. OUTREACH)

HEIGHT 62.96m
TOP OF 'A-FRAME'
ABOVE RAIL

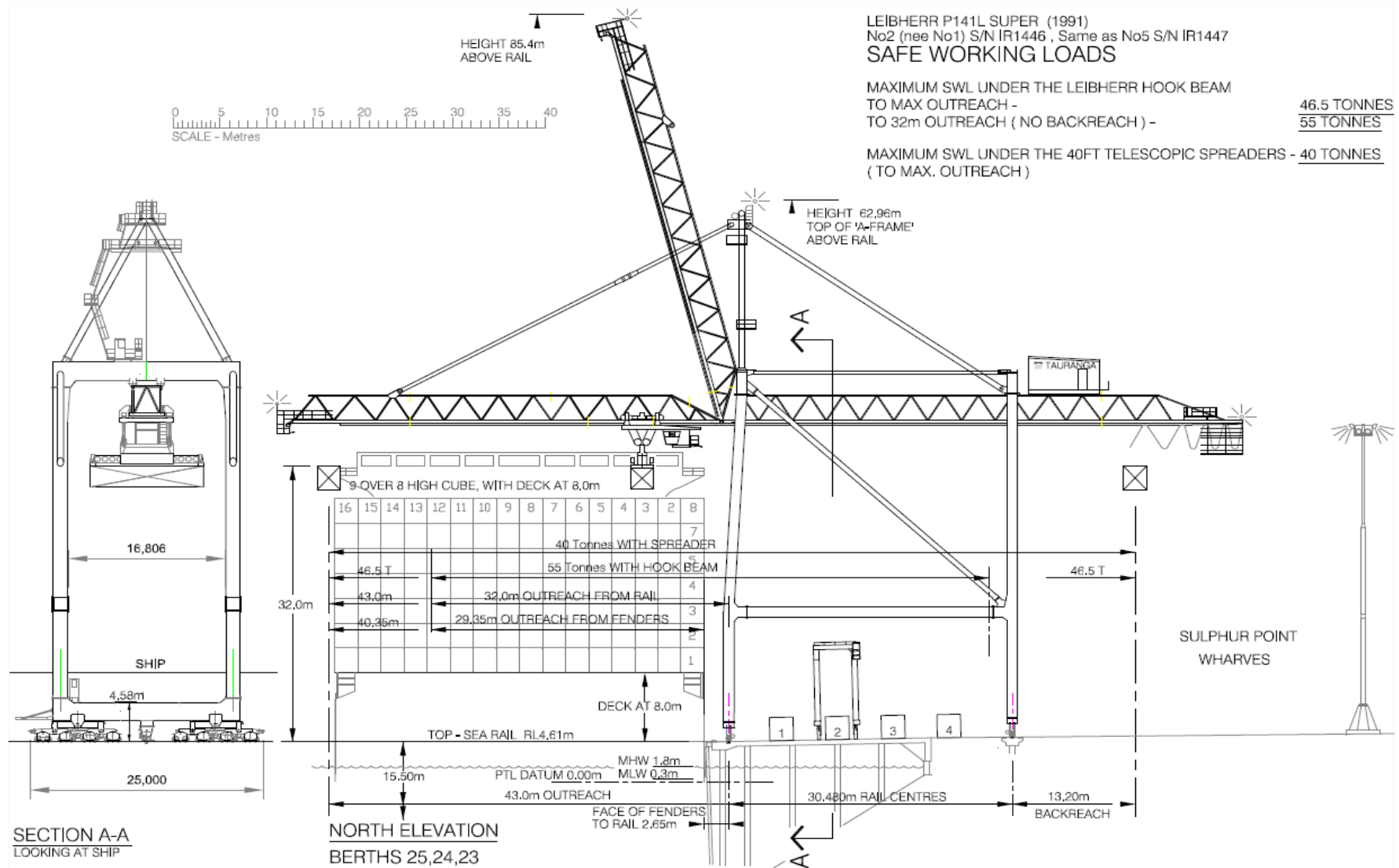

BOOM UP (PARK POSITION)
 HEIGHT 96,35m ABOVE RAIL
 100m above TCC (Moturik) Datum



LIEBHERR P 157 L SUPER (2009)
 No3 S/N IR1761
SAFE WORKING LOADS

MAXIMUM SWL UNDER THE LIEBHERR HOOK BEAM
 TO MAX OUTREACH & BACKREACH
 TO 40m OUTREACH (NO BACKREACH) -

70.9 TONNES
79.9 TONNES

MAX REACH UNDER THE 40FT TELESCOPIC SPREADERS #5&6
 MAX REACH UNDER THE TWINLIFT SPREADER

50 TONNES
2 x 30 TONNES

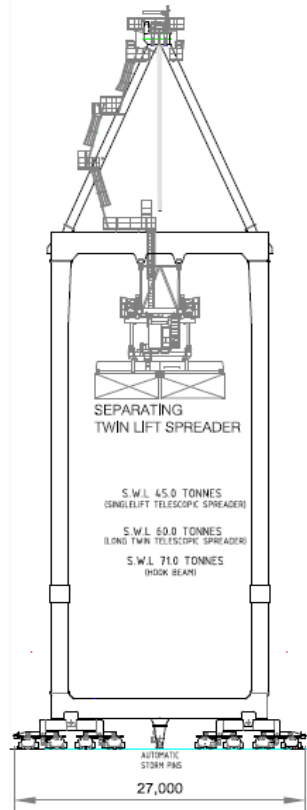

SECTION A-1

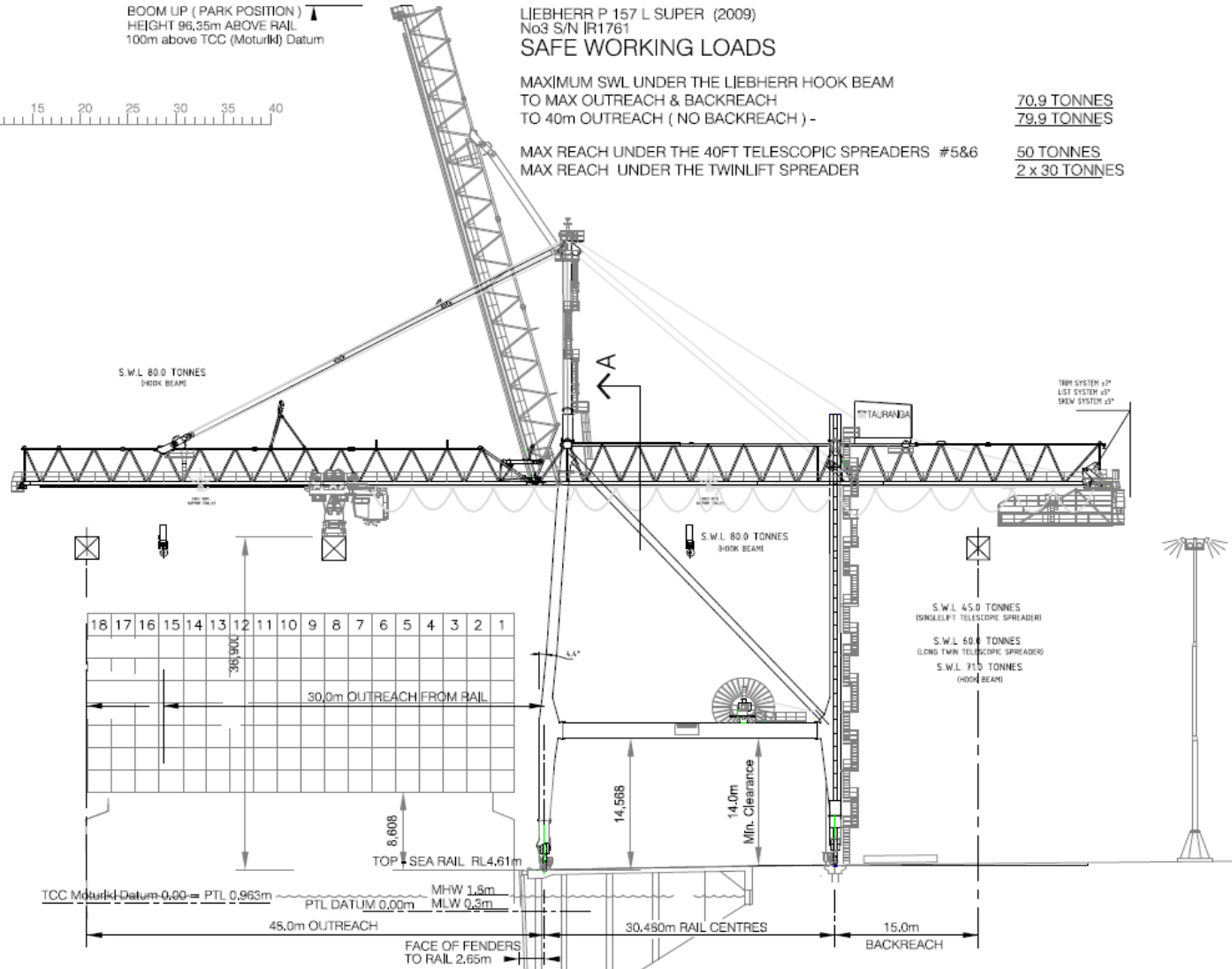

CRANE No.3 (5th) - LIEBHERR P 157 L SUPER IR1761
 DIMENSIONS & LOADS





BOOM UP (PARK POSITION)
HEIGHT 96,35m ABOVE RAIL
100m above TCC (Moturki) Datum

LIEBHERR P 157 L SUPER - TO BE COMMISSIONED 2014
No. S/N IR1875
SAFE WORKING LOADS

MAXIMUM SWL UNDER THE LIEBHERR HOOK BEAM
TO MAX OUTREACH & BACKREACH
TO 40m OUTREACH (NO BACKREACH) -

70,9 TONNES
79,9 TONNES

MAX REACH UNDER THE 40FT TELESCOPIC SPREADERS #5&6
MAX REACH UNDER THE TWINLIFT SPREADER

50 TONNES
2 x 30 TONNES

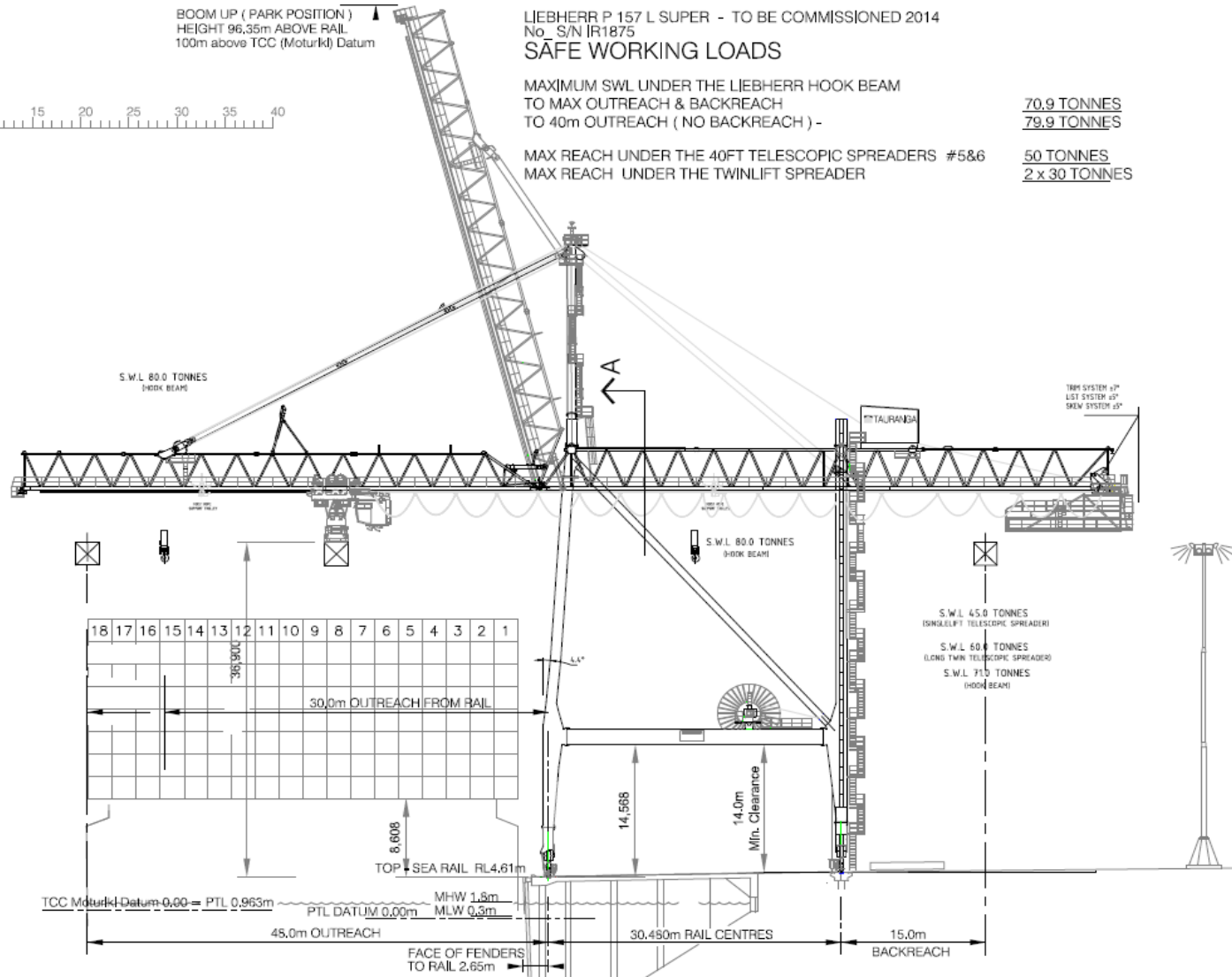
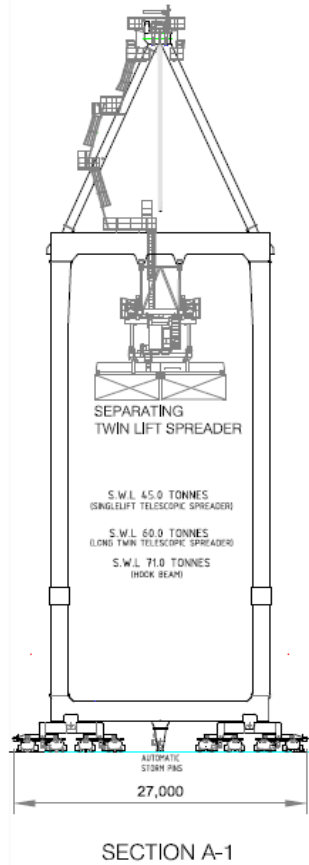

NEW (2014) CRANE No.4 (7th) - LIEBHERR P 157 L SUPER IR1875
DIMENSIONS & LOADS (Same as new No5 IR1850)



BOOM UP (PARK POSITION)
HEIGHT 96,35m ABOVE RAIL
100m above TCC (Moturki) Datum

LIEBHERR P 157 L SUPER - TO BE COMMISSIONED 2013
No. S/N IR1850
SAFE WORKING LOADS

MAXIMUM SWL UNDER THE LIEBHERR HOOK BEAM
TO MAX OUTREACH & BACKREACH
TO 40m OUTREACH (NO BACKREACH) -

70.9 TONNES
79.9 TONNES

MAX REACH UNDER THE 40FT TELESCOPIC SPREADERS #5&6
MAX REACH UNDER THE TWINLIFT SPREADER

50 TONNES
2 x 30 TONNES

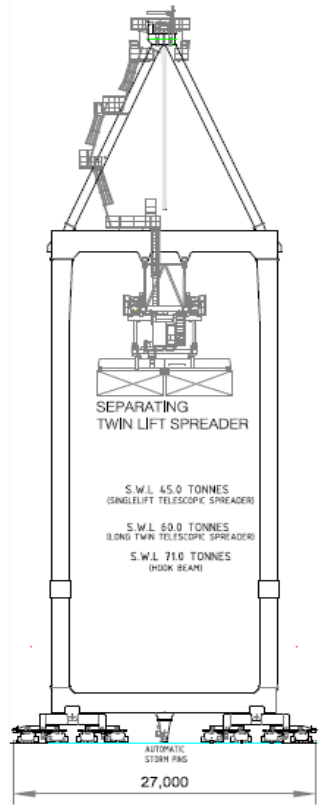

SECTION A-1

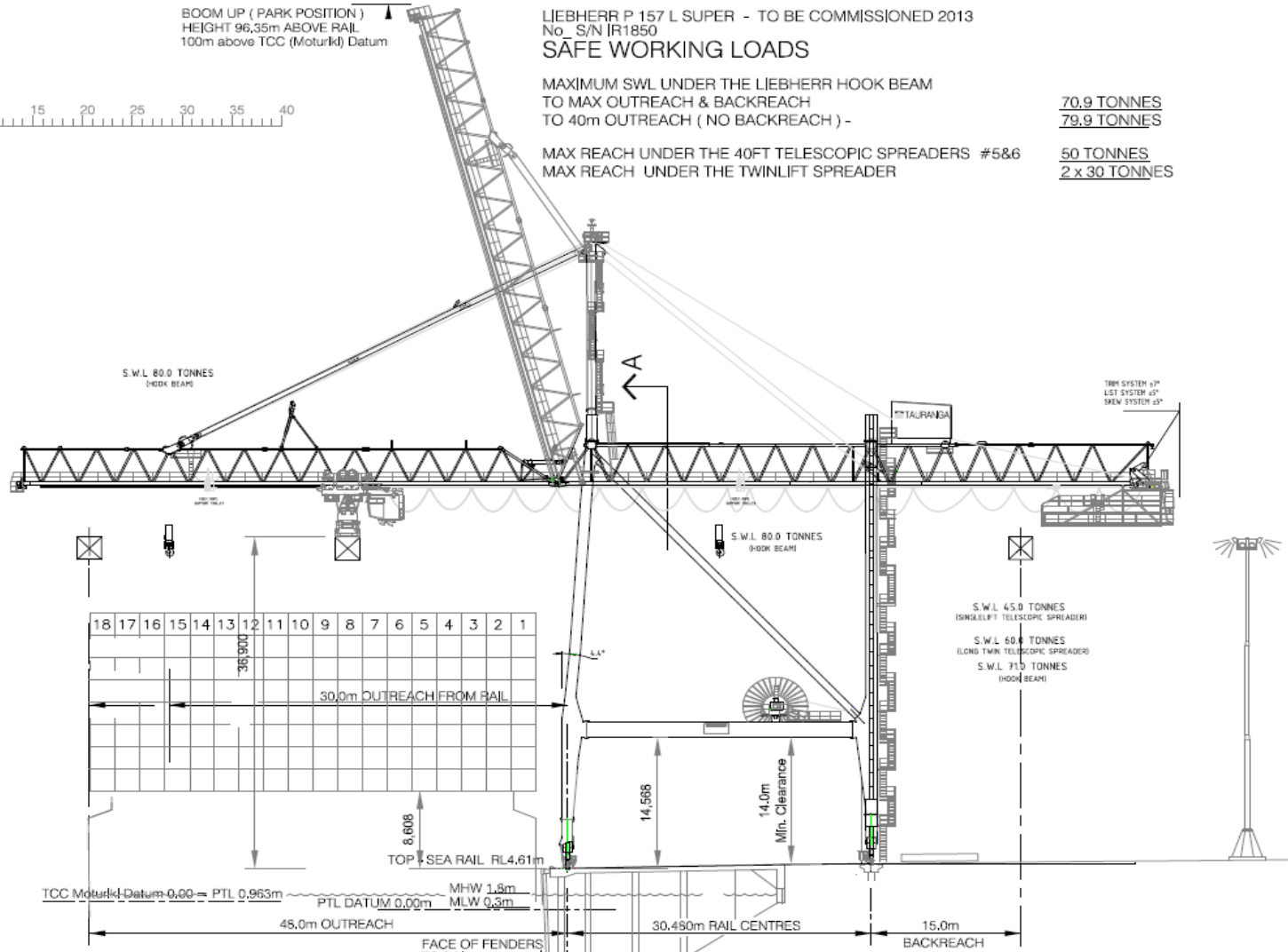

CRANE No.5 (6th) - LIEBHERR P 157 L SUPER IR1850
DIMENSIONS & LOADS

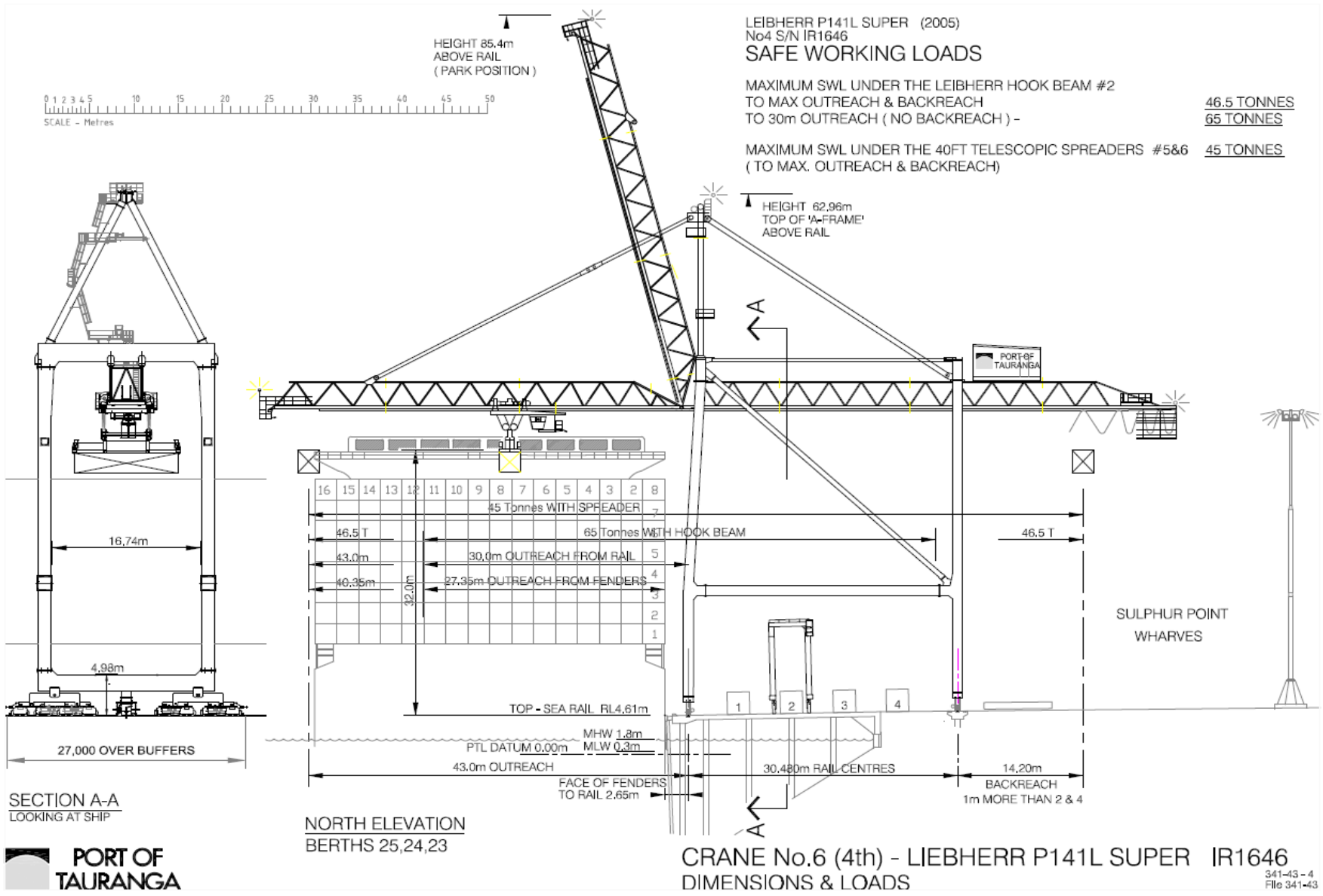

LEIBHERR P141L SUPER (2005)
 No4 S/N IR1646
SAFE WORKING LOADS

MAXIMUM SWL UNDER THE LEIBHERR HOOK BEAM #2
 TO MAX OUTREACH & BACKREACH **46.5 TONNES**
 TO 30m OUTREACH (NO BACKREACH) - **65 TONNES**

MAXIMUM SWL UNDER THE 40FT TELESCOPIC SPREADERS #5&6
 (TO MAX. OUTREACH & BACKREACH) **45 TONNES**

HEIGHT 85.4m
 ABOVE RAIL
 (PARK POSITION)

HEIGHT 62.96m
 TOP OF 'A-FRAME'
 ABOVE RAIL

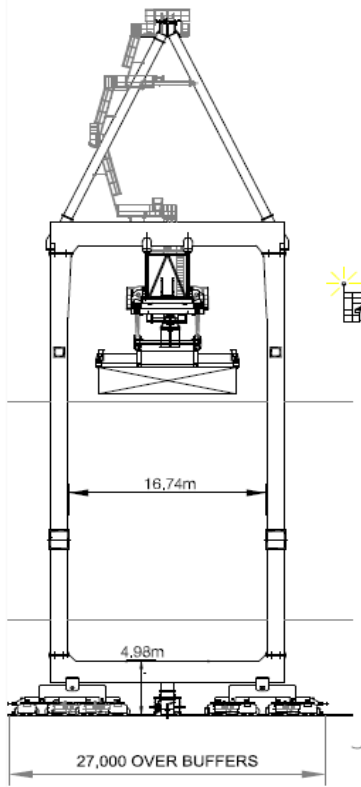

SECTION A-A
 LOOKING AT SHIP

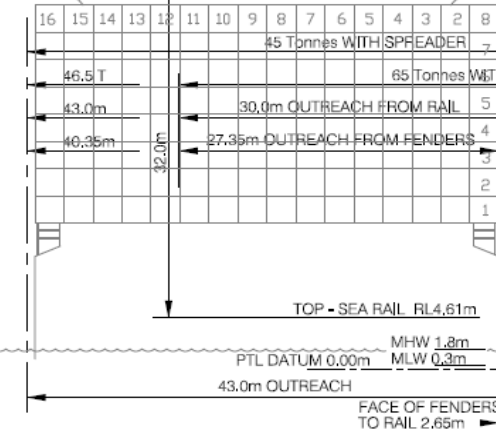

NORTH ELEVATION
 BERTHS 25,24,23

CRANE No.6 (4th) - LIEBHERR P141L SUPER IR1646
 DIMENSIONS & LOADS



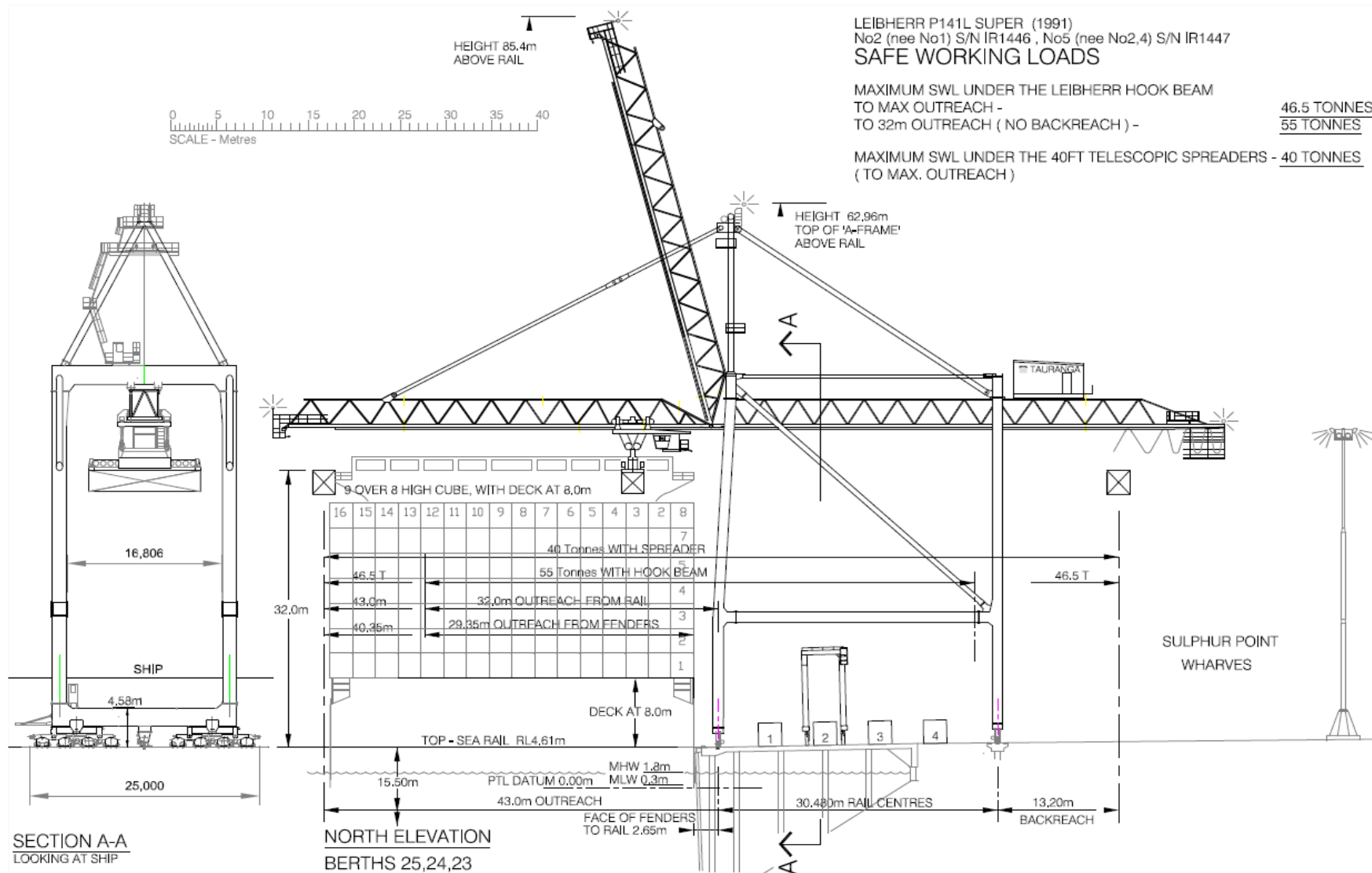

LEIBHERR P141L SUPER (1991)
 No2 (nee No1) S/N IR1446 , No5 (nee No2,4) S/N IR1447
SAFE WORKING LOADS

MAXIMUM SWL UNDER THE LEIBHERR HOOK BEAM
 TO MAX OUTREACH - 46.5 TONNES
 TO 32m OUTREACH (NO BACKREACH) - 55 TONNES

MAXIMUM SWL UNDER THE 40FT TELESCOPIC SPREADERS - 40 TONNES
 (TO MAX. OUTREACH)



CRANE No.7 (3rd) - LIEBHERR P141L SUPER - IR 1447
 DIMENSIONS & LOADS (Same as No2 IR1446)

Hoppers

The following hoppers are available:

- Two multi purpose hoppers 300 tonne capacity
- Two general purpose hoppers 250 tonne capacity
- Two general purpose hoppers 150 tonne capacity
- Two general purpose hoppers 100 tonne capacity
- Six Napier type hoppers 50 tonne capacity

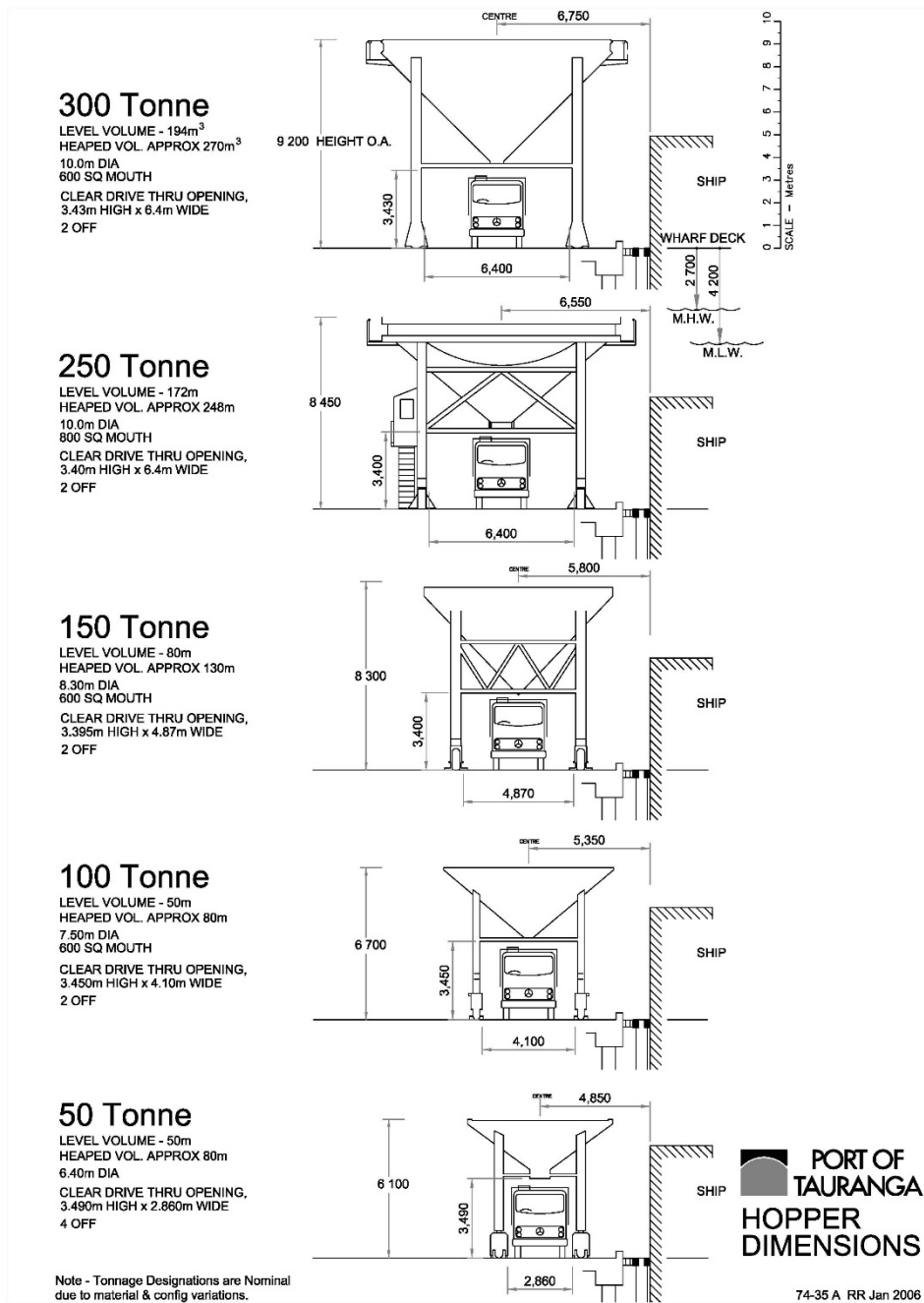

Port of Tauranga

Connecting New Zealand and the World

Silo

Capacity 3,000 tonnes - loading rate 120 tonnes/hr. Simultaneous load and discharge capability.

Storage silos - 5,000 tonne capacity.

Woodchips Belt Conveyor Loader and Slinger

Owned and operated by Wood Export Limited, capable of achieving loading rates of:
Woodchips - 750 tonnes/hour

Storage

Hard Wood Chip Storage on concrete base capacity – 65,000 tonnes.

Soft Wood Chip Storage on asphaltic concrete base – 70,000 tonnes.

Tanker/Bulk Cement Discharge Berth

Cement	-	16" diameter pipe	-	discharge rate 350 tonnes/hour
White Oil	-	300mm 100 psi	-	discharge rate 650,000 to 850,000 litres/hour
Bitumen	-	300mm 125 psi	-	500,000 litres/hour
HFO	-	250mm 125 psi	-	500,000 litres/hour
Chemicals	-	1 x 6" diam.; 1 x 8" diam.		
Molasses	-	1 x 14" diam.		

Coal Facility

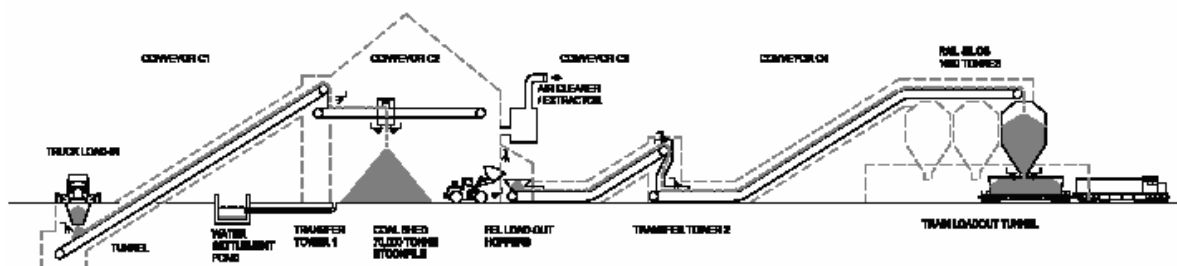

COAL FACILITY - DIAGRAMMATIC

The Port of Tauranga coal transit and storage facility is the only fully-enclosed coal store in Australasia. The \$30-million complex was purpose-built in 2004, as an environmentally-sound means of receiving and storing up to two shipments (70,000 tonnes).



Port of Tauranga

Connecting New Zealand and the World

The only similar facility in Australasia has been decommissioned, while two other coal storage facilities in New Zealand - Lyttelton and a new one currently under construction in New Plymouth - are both exposed to the environment.

Dust nuisance from the Tauranga facility is controlled mainly by the fact of containment in a closed structure, with the store itself and all conveyors being fully-enclosed and dust-proofed. At the end of conveyors, the opportunity for dust-creation is limited by fine, chemically-treated water sprays.

Any dust raised by loaders working within the negative-pressure store area is controlled by moisture levels on the floor, with air being filtered before being discharged outside by a large cascade water filter.

Within the rail silos, dust is filtered by fabric Luhr filters. Each of the 30 rail wagons per train is loaded within a 50-metre long concrete tunnel, to control dust and noise. Water, used for washing down and dust-filtering, is collected in settling ponds or chambers and is either recycled or discharged into the sewerage system as trade waste.

Container Wash

Container washing facilities are available at Mount Maunganui and Tauranga Wharves.

Cargo Storage

Both open and covered storage areas are available within the Port complex. Outside storage comprises about 33.5 hectares of sealed hardstanding.

Hewletts Road storage metalled area - 4.5 hectares.

On-wharf cargo sheds are:

Mount Maunganui Wharf

- No 1 North, 1,949 sqm (Transit, coolstores, kiwifruit)
- No 1 South, 1,949 sqm + 2,178 sqm (verandahs)
- No 2 3,730 sqm dry cargo
- No 3 4,117 sqm
- No 4 4,614 sqm, 1,624 sqm (No 4 north), 2,991 sqm (No 4 south)
- No 5 2,964 sqm (Main shed), 1,432 sqm (No 5 north)
- No 7 Cargo shed 4,077 sqm
- No 8 Cargo Shed 770 sqm
- No 9 1,035 sqm plus 334m (verandah)



Port of Tauranga

Connecting New Zealand and the World

Coldstore: 22,500 m² (20,300 tonne cap) (Owned and operated privately)

Off wharf, petroleum products tank storage, 115,000 tonne, cement storage 8,800 tonne, fertiliser storage, seven hectares. Covered bulk storage for methanol and caustic soda. Salt refinery over 100,000 tonne annually.

Coal storage facility: 70,000 tonne capacity, conveyor infeed from Port, conveyer outfeed to silos for discharge to rails.

Reefer Points: 240

Sulphur Point Wharf

No 11 10,400 m² and 1,180 (verandah)

No 12 13,448 m² and 1594 (verandah).

Cold storage 10,000 tonne capacity (Private lease)

Dairy Industry

Storage Shed 137,068 (private lease).

Storage Shed 148,342 m² (private lease).

Storage Shed 15 6,930 m²

And 19.8 hectares paved terminal storage for containers and general cargo.



Port of Tauranga

Connecting New Zealand and the World

Stevedoring

Stevedoring is the process of loading vessels and stowing cargo. This service is provided at the Port of Tauranga by privately-owned companies under contract to exporters, importers or shipping companies. Stevedoring companies employ their own workforce and directly service their own customers.

C3 Limited

Private Bag 12501
Tauranga Mail Centre
Tauranga 3143

Phone: 07 572 8972
Fax: 07 572 8933
Email: mountstevedoring@c3.co.nz
Website: www.c3.co.nz
Phone: 0800 SOLUTIONS
0800 765 884
General Cargo Ph: 07 572 8448
General Cargo Fax: 07 572 8438

ISO Limited

PO Box 4169
Mount Maunganui South
Mount Maunganui 3149

Phone: 07 577 7600
Mobile: 027 591 7093
Fax: 07 574 0610
Email: opsman@iso.co.nz
Website: www.iso.co.nz

Independent Stevedoring Limited

PO Box 14385
Tauranga Mail Centre
Tauranga 3143

Phone: 07 547 4546
Fax: 07 574 8387
Email: isl@independentstevedoring.co.nz
Website: www.independentstevedoring.co.nz

New Zealand Marshalling and Stevedoring

PO Box 5323
Mount Maunganui 3150

Phone: 07 574 6931
Fax: 07 575 9575
Email: operations@nzmstevedoring.co.nz
Website: www.nzmarshallingandstevedoring.co.nz



Port of Tauranga

Connecting New Zealand and the World

Marshalling

Marshalling, as distinct from stevedoring, is receiving cargo from road or rail transport and loading and assembling it on the wharf ready for export. In the case of imports, marshallers remove cargo from the wharves and prepare it for dispatching.

Like the stevedoring companies, marshallers are employed under contract and provide services directly to exporters, importers and shipping companies.

C3 Limited (Marshallers)

Private Bag 12501
Tauranga Mail Centre
Tauranga 3143

Phone: 07 572 8972
Fax: 07 572 8933
Email: solutions@c3.co.nz

Website: www.c3.co.nz

Phone: 0800 SOLUTIONS
0800 765 884
General Cargo Ph: 07 572 8448
General Cargo Fax: 07 572 8438

Independent Stevedoring Limited

PO Box 14385
Tauranga Mail Centre
Tauranga 3143

Phone: 07 547 4546
Fax: 07 574 8387
Email: isl@independentstevedoring.co.nz

Website: www.independentstevedoring.co.nz

ISO Limited

PO Box 4169
Mount Maunganui South
Mount Maunganui 3149

Phone: 07 577 7600
Mobile: 027 591 7093
Fax: 07 574 0610
Email: opsman@iso.co.nz

Website: www.iso.co.nz

New Zealand Marshalling and Stevedoring

PO Box 5323
Mount Maunganui

Phone: 07 574 6931
Fax: 07 575 9575
Email: operations@nzmstevedoring.co.nz
Website: www.nzmarshallingandstevedoring.co.nz

Quality Marshalling Mount Maunganui Ltd

PO Box 4344
Mount Maunganui South
Mount Maunganui 3149

Phone: 07 572 6508
Fax: 07 575 0144
Email: qm@qm.co.nz
Website: www.qm.co.nz



Port of Tauranga

Connecting New Zealand and the World

Warehousing and Logistics

Cargo packing is the process of receiving loose cargo from trucks or rail wagons and packing it into containers for export.

C3 Limited (Warehousing)

Private Bag 12501
Tauranga Mail Centre
Tauranga 3143

Phone: 07 572 8951
Fax: 07 572 9544
Email: mountwarehouse@c3.co.nz
Website: www.c3.co.nz
Free Phone: 0800 SOLUTIONS
0800 765 884
General Cargo Ph: 07 572 8448
General Cargo Fax: 07 572 8438

ISO Limited

PO Box 4169
Mount Maunganui South
Mount Maunganui 3149

Phone: 07 577 7600
Mobile: 027 591 7093
Fax: 07 574 0610
Email: opsman@iso.co.nz
Website: www.iso.co.nz

NZL Group Limited

PO Box 4052
Mount Maunganui South
Mount Maunganui 3149

Phone: 07 928 7401
Fax: 07 928 7484
Email: karl.cameron@nzlgroup.co.nz
Website: www.nzlgroup.co.nz

CSN Tauranga

PO Box 4506
Mount Maunganui South
Mount Maunganui 3149

Phone: 07 571 2651
Fax: 07 928 4313
Email: graeme.james@csnbop.co.nz
Website: www.csn.co.nz

Woodland Management Ltd

112 Hull Road
Mount Maunganui 3116

Phone: 07 575 3233
Fax: 07 575 7833
Email: dion@woodlandmgt.co.nz
Website: www.woodlandmgt.co.nz



Port of Tauranga

Connecting New Zealand and the World

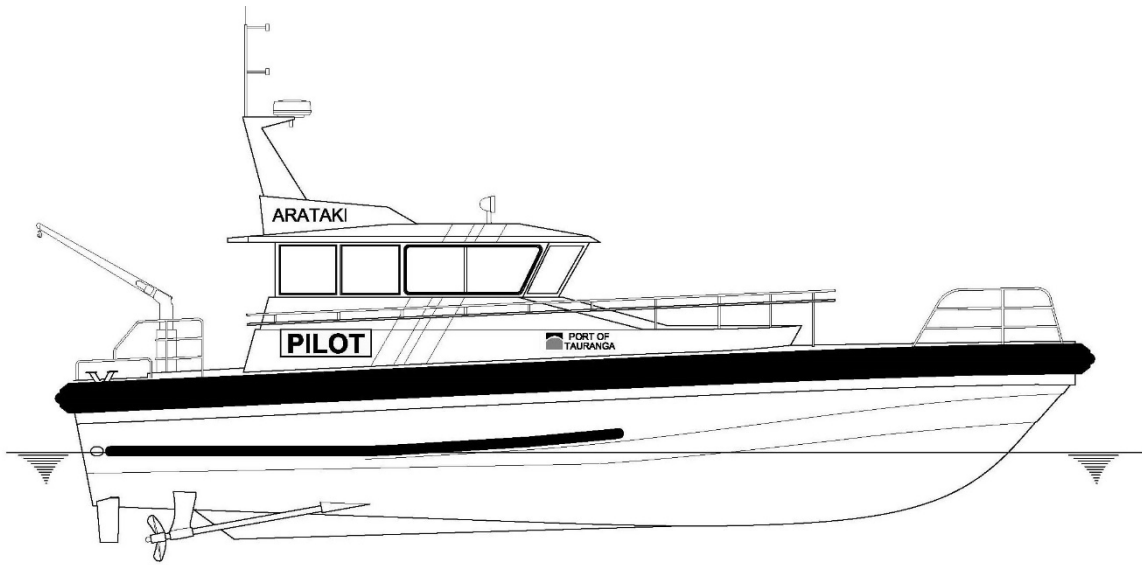

"ARATAKI"

Builder:	Q-West Boat Builders Ltd, Wanganui
Length:	16.5m
Beam:	5.4m
Design Draught:	1.1m
Main engines:	2 x 750kw Scania DI 1643M
Propulsion:	2 x Henleys fixed pitch propellers
Speed:	Max: 30 knots Cruising: 26 knots



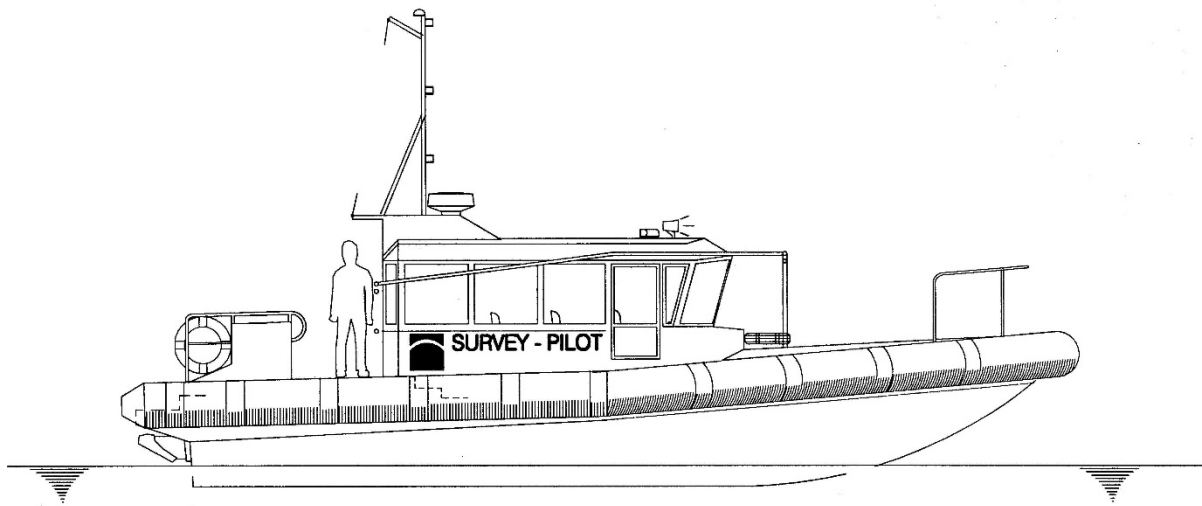

SURVEY / BACK-UP PILOT LAUNCH "TE AWANUI"

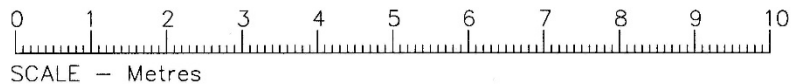

Completed March 1998 *Te Awanui* is an all aluminium vessel designed by Naiad Inflatable's at Picton. Designed to undertake duties as a hydrographic survey vessel other duties will include back up to the pilotage service as a service as a standby pilot vessel. Details are:

Length:	12.6m
Beam:	3.85m
Draught:	0.7m
Engines:	2 x 450 HP Volvo Diesels
Propulsion	2 x H291 Hamilton Jets
Speed:	35 knots





ROBERT ALLAN LTD.

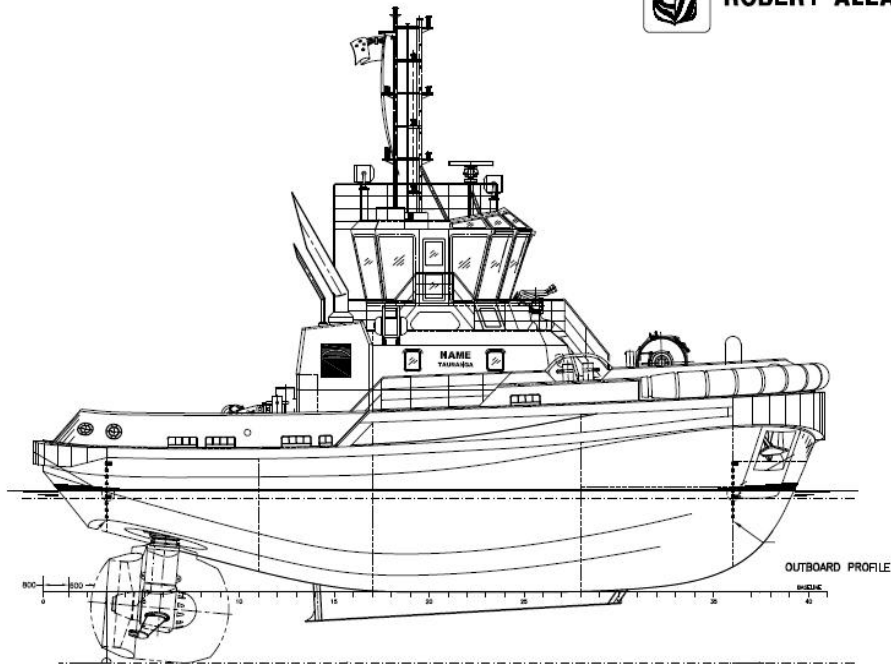

TAI PARI and TAI TIMU

RAMparts 2500W Tugs

Tug Names	<i>Tai Pari and Tai Timu</i>
Port of registry	Tauranga
Class Notation	100A1 Tug, +LMC, +UMS, *IWS for restricted service (fire fighting ½ Tai Pari Only)
Designer / Design	Robert Allan / RAMparts 2500w
Builder	Cheoy Lee
Engines / Power	2 x Caterpillar 3516C(HD) - 2350kW (3150BHP) @ 1800RPM
Drive type (Azimuth)	Rolls Royce US 255 FP, 2.6m dia, Ratio 7.516:1
Number of shafts	2 x
Length overall (LOA)	24.40m LoA
Registered length	23.071m
Beam	11.25m
Draft	~5.45m
Gross tonnage	510
Date of build	April 2015 and May 2015
Bollard Pull	73 over stern / 72 over bow
Free Running speed	12.8 Knots
Side Stepping	>5knots



Port of Tauranga

Connecting New Zealand and the World

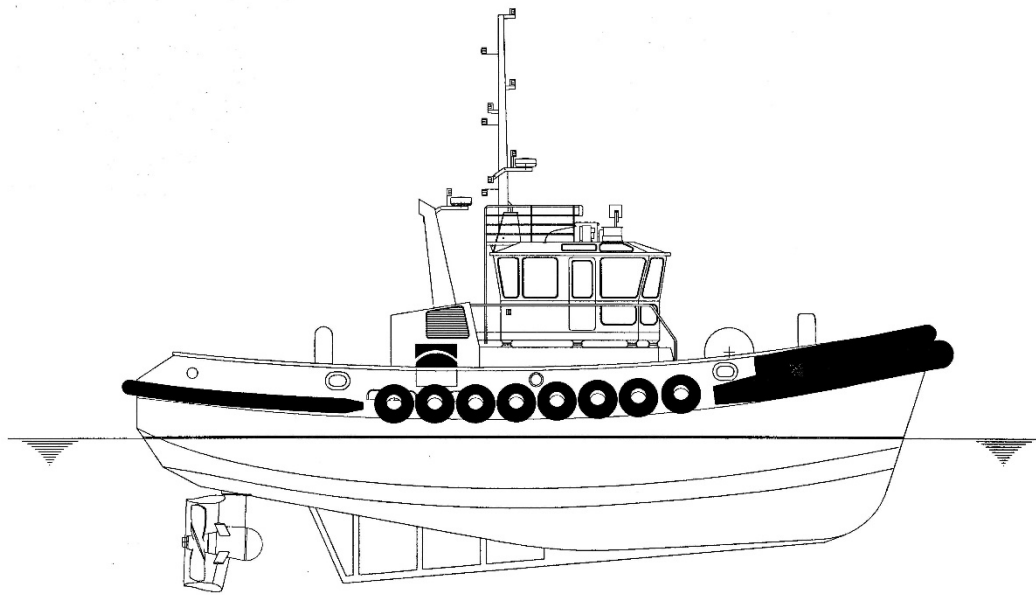

TUG "SIR ROBERT"

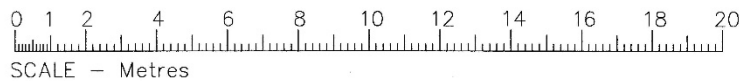

Length overall:	22.2m (excluding fenders)
Beam:	9.2m
Draft (maximum):	4.35m
Displacement:	338 tonnes
Engines:	2 x Caterpillar 3516 EUI Marine Diesels Each producing 1641kw (2200 HP) at 1800 RPM
Propulsion:	2 Ulstein 1650H thruster units Propeller diameter 2.184m
Bollard pull:	50 tonnes
Speed:	12 knots

Built by Whangarei Engineering Limited in Whangarei and delivered in November 2000 – classed +100 AISSC, mono hull work boat, 63.



Port of Tauranga

Connecting New Zealand and the World